

Keep the tunnel from freezing with the Tunnel Heater

ANTIFREEZE TO WATER RATIO SHOULD BE 50-50.

TO DETERMINE GALLON CAPACITY:
HEAT EXCHANGER = 3.5 GAL.
AVERAGE BOILER = APPROX. 2 TO 2.5 GAL.
EXPANSION TANK = APPROX. 12 GAL.
2 1/2" Ø PIPE = .16 GAL. PER LIN. FT.
2" Ø PIPE = .128 GAL. PER LIN. FT.

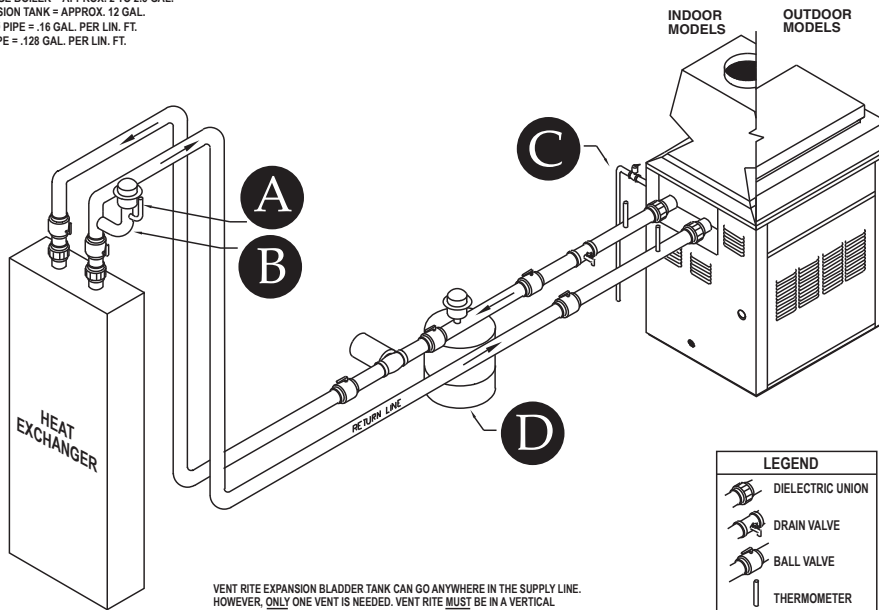

VENT RITE EXPANSION BLADDER TANK CAN GO ANYWHERE IN THE SUPPLY LINE. HOWEVER, ONLY ONE VENT IS NEEDED. VENT RITE MUST BE IN A VERTICAL POSITION EITHER ON THE TOP OR THE BOTTOM OF THE PIPE.

THE LINE FOR ADDING ANTIFREEZE CAN BE INSTALLED ANYWHERE ALONG THE RETURN LINE. HOWEVER, THE TOP OF THE FILL LINE MUST BE HIGHER THAN ANY OTHER POINT ON THE SYSTEM.

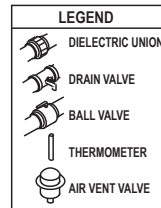

Hot Air System - Tunnel Heater

EQUIPMENT

- A** AIR VENT
- B** FILL LINE 2" MINIMUM
- C** RELIEF VALVE
- D** EXPANSION TANK

NOTE: Wiring and controls to be provided by the purchaser. Additional motor specifications available upon request. Additional voltages available on special order.

GENERAL DESCRIPTION

The Tunnel Heater is the perfect partner for your Proto-Vest Drying System. By utilizing the tremendous air distribution from the drying system, this option creates the most efficient way to heat your tunnel. The hydronic heating boiler is sized for your climatic zone and can be installed in your back room or any out-of-the-way location. Proto-Vest's stringent standards in material selection result in extended life and reduced maintenance.

FEATURES / BENEFITS

Save on Energy:

The Tunnel Heater is the most efficient method of heating a carwash ever invented. It uses the tremendous air distribution provided by your Proto-Vest drying system to heat your whole tunnel. Its electronic outdoor reset control system gives you the ultimate control and fuel economy. The Tunnel Heater gives you 100% return on your B.T.U.

Effective:

Minimize pipes from freezing and ice build-up. Adding heat to your drying system will dry cars more efficiently.

SERVICE / SUPPORT

Proto-Vest recognizes that support after the sale of equipment is critical to the success of our customers. Our company offers its customers access to a wide range of services including: field service technicians, factory direct aftermarket parts, and an engineering staff for custom designed applications.

Proto-Vest Patents:

U.S.: 3,942,430; 4,161,801; 4,409,035; 4,418,442; 4,433,450; 4,445,251; 4,446,592; 4,589,160; 4,700,426; 5,027,714; 5,184,369; 5,187,881; 5,195,207; 5,280,665; 5,421,102; 5,553,346; 5,886,648; 5,901,461; 5,950,324; 5,960,564; 6,038,781; 6,176,024; 6,519,872; others pending.

Canada: 1,021,996; 1,111,328; 1,190,453; 1,201,040; 1,197,439; 1,219,195; 1,219,192; 1,219,194; 1,258,026; 1,219,193; 2,013,749; 2,071,568; 2,071,239; 2,071,388; others pending.



Specifications subject to change without notice.

Proto-Vest, Inc., 7400 N. Glen Harbor Blvd., Glendale, AZ 85307 • 800-521-8218 • 623-872-8300 • Fax 623-872-6150
www.proto-vest.com

© Copyright 1998, Proto-Vest, Inc. All rights reserved.